

RoHS Compliant

REV	ECN No.	DATE	REMARK
A0	NEW	2024.7.1	NEW RELEASE

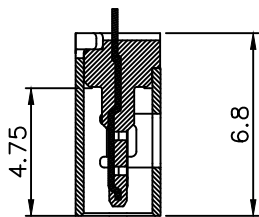

SECTION A-A

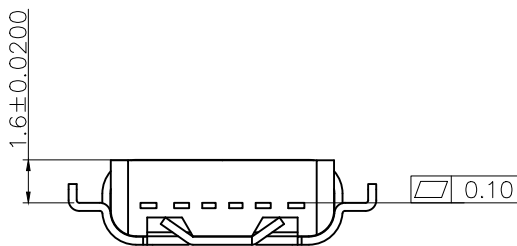
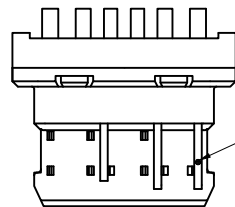

胶芯主体

接触区域镀金测点

备注:

1. 材质:

1.1 胶芯: LCP E130I, UL94V-0

1.2 端子: 黄铜C2680 : 镍底30U" MIN

接触区域镀金G/F, 焊接区域镀金G/F

1.3 外壳: SUS201, T=0.30mm : 表面镀镍40U" MIN

1.4 中夹片: SUS201

2. 主要特性:

2.1 额定电流: 3A

2.2 接触阻抗: 40mΩ MAX (初始值)

50mΩ MAX (测试后)

2.3 绝缘阻抗: 100MΩ MIN

2.4 耐压测试: 100V AC R M S

2.5 整体插入力: 5-20N 整体插入力: 5-20N (耐久后)

整体拔出力: 8-20N 整体拔出力: 6-20N (耐久后)

2.6 耐久: 10000次

2.7 耐高温: SMT回流焊(峰值260°±5°), 塑胶不能有起泡, 融胶等不良, 变色, 翘曲变形在公差范围以内。

2.8 产品须做锡焊测试, 粘锡面积达到95%以上:

2.9 盐雾测试: 24H MIN

3.0 工作温度: -25°C ~ +80°C

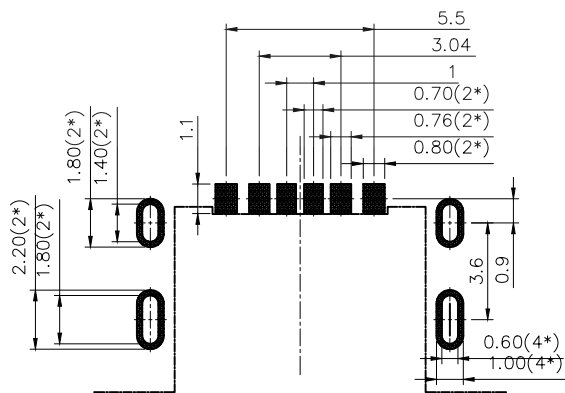
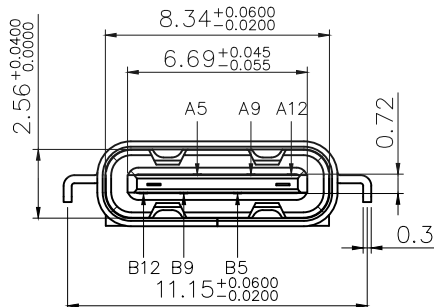
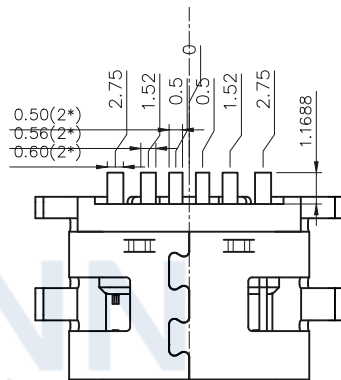
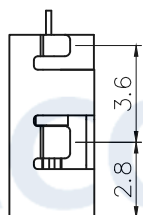
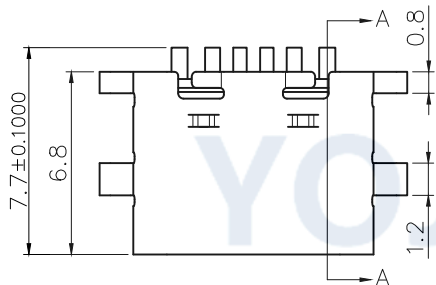

RECOMMENDED P.C.B. LAYOUT
TOLERANCE UNSPECIFIED ±0.05mm

USB TYPE-C PIN ASSIGNMENTS

PIN NUMBER	SIGNAL NAME	PIN NUMBER	SIGNAL NAME
A5	CC1	B12	GND
A9	VBUS	B9	VBUS
A12	GND	B5	CC2

GENERAL TOLERANCES		深圳市跃佳电子有限公司 SHENZHEN YOJACONN ELECTRONICS CO.,LTD.	
x.xxxx	± ---	TITLE TYPE-C母座6P沉板1.6四脚插CH0.02 长6.8Z3带夹片	PART NO. CF6S16-4DS68Z3-002SN10
x.xxx	± 0.10		
x.xx	± 0.25		
x.x	± 0.30		
ANGULAR	± ---°		
DRAWN BY	XGC 2024.5.30	UNIT	MM
CHECKED BY	ZKX 2024.5.30	SIZE	A4
APPROVED BY	LLQ 2024.7.1	DWG NO.	CF06-029
		SCALE	PROJECTION
		SHEET 1 OF 1	